

Glazing Properties

MATERIAL TYPE	THICKNESS	← COLOR (Standard Colors Bold)	ASTM (D)→		Light Transmission (%)	Solar Energy Transmission (%)	Shading Coefficient	Solar Heat Gain Coefficient	Sound Reduction (dB)	U-Factors in BTU/(hour)(sq.ft.)(°F)	Specific Gravity / Relative Density	Tensile Strength (K)	Tensile Modulus of Elasticity (K)	Flexural Strength (K)	Izod Impact Strength - Molded Notch	Rockwell Hardness (M)	Deflection Temperature 264 psi (1.8 MPa)	Visible Reflectance % (Out)	UV Transmittance (%) ¹	
			1003								1363	792	638	638	790	256	785	648		
ACRYLIC	STANDARD	0.118"	Clear	92	89	.98	.85	22	.98	1.19	10	400	17	93					100	
			2447 White	49	63	.74	.64	22	.98	1.19	10	400	17	93						0
			7328 White	30	34	.43	.37	22	.98	1.19	10	400	17	93						0
			2412 Bronze	27	35	.61	.53	22	.98	1.19	10	400	17	93						100
			2370 Bronze	10	20	.45	.35	22	.98	1.19	10	400	17	93						100
			2064 Gray	25	42	.72	.63	22	.98	1.19	10	400	17	93						100
			Clear over Clear	85	79	.96	.72	22	.98	1.19	10	400	17	93						100
			2447 White over Clear	45	56	.73	.54	25	.68	1.19	10	400	17	93						0
			7328 White over Clear	23	30	.42	.37	25	.68	1.19	10	400	17	93						0
			2447 White over 2412 Bronze	13	22	.45	.34	25	.68	1.19	10	400	17	93						0
			2447 White over 2447 White	24	40	.55	.41	25	.68	1.19	10	400	17	93						0
			2447 White over 2064 Gray	12	26	.53	.40	25	.68	1.19	10	400	17	93						0
			2412 Bronze over Clear	25	31	.60	.45	25	.68	1.19	10	400	17	93						100
			2370 Bronze over Clear	9	18	.44	.30	25	.68	1.19	10	400	17	93						100
	2064 Gray over Clear	23	37	.71	.54	25	.68	1.19	10	400	17	93						100		
	COMMERCIAL DUTY	0.177"	2447 White	37	47	.56	.48	25	.94										0	
			7328 White	21	24	.30	.26	25	.94										0	
			2412 Bronze	27	35	.61	.53	25	.94										100	
			2370 Bronze	10	20	.45	.35	25	.94										100	
			2064 Gray	25	42	.72	.63	25	.94										100	
			2447 White over Clear	34	42	.55	.41	28	.64										0	
			7328 White over Clear	19	21	.29	.22	28	.64										0	
			2412 Bronze over Clear	25	31	.60	.45	28	.64										100	
			2370 Bronze over Clear	9	19	.36	.27	28	.64										100	
			2064 Gray over Clear	23	37	.71	.54	28	.64										100	
	DR ²	0.177"	30% Clear (Single)	92	See Single 0.187" Colors 2412 Bronze, 2447 White or Clear	28	.68	1.18	9	376	13.7	.6	78	198	Dependent on Color					
			50% Clear (Single)	92		28	.68	1.17	8	340	12	.7	69	194						
			70% Clear (Single)	90		28	.68	1.16	7.1	304	10.6	.9	59	190						
100% Clear (Single)			90	28		.68	1.15	5.6	250	8.3	1.1	46	185							
30% (Double)			36	See 0.177 Double Colors	31	.68	1.18	9	376	13.7	.6	78	198							
50% (Double)			36		31	.68	1.17	8	340	12	.7	69	194							
70% (Double)			34		31	.68	1.16	7.1	304	10.6	.9	59	190							
100% (Double)			34		31	.68	1.15	5.6	250	8.3	1.1	46	185							

GLASS TYPE	Thickness	Color	Light Transmission (%)	Solar Energy Transmission (%)	Shading Coefficient	Solar Heat Gain Coefficient	U-Factors in BTU/(hour)(sq.ft.)(°F)	Tensile Strength (K)	Visible Reflectance % (Out)	UV Transmittance (%) ¹	↓ MORE INFORMATION ↓
PREMIUM INSULATED	1.125"	Bronze	40	15	.31	.20	.22 ³	65	8	0	¹ 100% UV transmission can be paired with a UV clear which will block the UV (not available with the DR options) ² Damage Resistant (Impact Modified Acrylic) ³ Winter .23 / Summer .20 ⁴ <16 sqft = 1.125" thickness, >16 sqft = 1 3/16" thickness ⁵ Winter .97 / Summer .88
		Gray	32	12	.33	.18	.22 ³		7	0	
		Clear	60	22	.44	.27	.22 ³		11	0	
NBE INSULATED	1"	Bronze	42	32	.52	.45	.33		8	14	
		Gray	36	27	.46	.40	.33		7	13	
		Clear	73	52	.77	.67	.33		17	37	
TEMPERED LAMINATED	0.500"	Bronze	36	14	.41	.36	.93 ⁵	13	<1		
		Gray	30	12	.41	.36	.93 ⁵	13	<1		
		Clear	60	23	.36	.32	.93 ⁵	16	<1		

GLASS:: All glass is tempered with a LoE coating on the exterior glass. Premium insulated glass has an argon-filled airspace in-between the tempered and the interior tempered/laminated glass. Tempered / laminated glass is two pieces of glass with an 0.030" PVB interlayer and is clear by default (White laminate is available but has to be specifically requested and blocks visibility.) Generally, 1/4" tempered is used over 2- 3/16" pieces for larger skylights and smaller can be 3/16" tempered over 2- 0.100 pieces for the laminate. At times, the thickness of everything may be increased or decreased—depending on the application. Laminated glass is the new safety glass, taking chicken-wire glass' place. Clear glass with white laminate will look green unless low iron glass is used. Bronze or gray glass and white laminate will not show the green hue of the glass.

MATERIAL	TYPE	THICKNESS	← COLOR	ASTM →	Light Transmission (%)	Solar Energy Transmission	Shading Coefficient	Solar Heat Gain Coefficient	Sound Reduction	U-Factors in BTU/(hour)(sq.ft.)(°F)	Specific Gravity / Relative Density	Tensile Strength	Tensile Modulus of Elasticity	Flexural Strength	Izod Impact Strength – Molded Notch	Rockwell Hardness	Deflection Temperature 264 psi (1.8 MPa)	Visible Reflectance % (Out)	UV Transmittance (%)	
					1003					792	638	638	790	256	785	648				
POLYCARBONATE	STANDARD	0.125"	Clear		86	89	1.02	.85	22	.93		9.5	340	13.5	18	70	270		100	
			Gray / Bronze		50	39	.7	.53	22	.93		9.5	340			18	R11 _g	270		0
			White		34	34	.43	.37	22	.93										0
			White over Clear		29	30	.42	.37	25	.65										100
			Gray/Bronze over Clear		43	34	.66	.45	25	.65										
	STRUCTURED / MULTI WALL	6MM	Twin Wall	Clear		80		.91	.8	24	.62									0
				Bronze		25		.76	.66	24	.62									0
				Opal (White)		60		.76	.66	24	.62									0
		8MM	Twin Wall	Clear		80		.94	.82	28	.53									0
				Bronze		25		.8	.70	28	.53									0
				Opal (White)		60		.75	.65	28	.53									0
			Triple Wall	Clear		75		.94	.82	28	.53									0
				Bronze		23		.8	.75	28	.53									0
				Opal (White)		60		.75	.64	28	.53									0
	10MM	Twin Wall	Clear		80		.94	.82	30	.48									0	
			Bronze		25		.86	.75	30	.48									0	
			Opal (White)		55		.74	.64	30	.48									0	
		Triple Wall	Clear		75		.86	.75	30	.48									0	
			Bronze		23		.65	.57	30	.48									0	
			Opal (White)		55		.71	.62	30	.48									0	
	16MM	Five Wall	Clear		62		.78	.68	36	.34									0	
			Bronze		25		.57	.50	36	.34									0	
			Opal (White)		40		.52	.45	36	.34									0	
		X-Strong	Clear		62		.78	.68	36	.35									0	
			Bronze		20		.57	.50	36	.35									0	
			Opal (White)		40		.52	.45	36	.35									0	
	25MM	Five Wall	Clear		60		.61	.61	45	.26									0	
			Bronze		20		.57	.50	45	.26									0	
			Opal (White)		25		.62	.54	45	.26									0	

STRUCTURED / MULTIWALL POLYCARBONATE PROFILES



TWIN

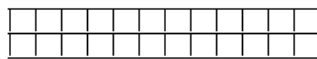

TRIPLE

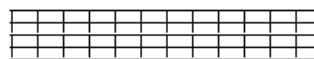

FIVE WALL



X-STRONG

ACRYLIC

Design Loads:: Safer than glass because of greater breakage resistance and breaks into larger pieces. Complies with American National Standards Institute (ANSI) Z97.1-1975, Safety Glazing for Buildings. Tensile strength is 10,000 psi at room temperature ASTM D638-room temperature=68°F/20°C, continuous loads below this value can induce stress-crazing. Continuously imposed design loads should not exceed 1,500 psi. In other applications involving continuous loading, loads should be less than 750 psi at 23°C (73°F). **Light Transmission::** All thickness of colorless acrylic transmit 92% of visible light. White light transmission decreases as thickness increases. Bronze and Gray light transmission is the same for all thicknesses. Colorless is warranted for seven years not to lose more than 3% in light transmission. Items marked with ** are standard shades. Some colors may have availability or size restrictions. **Cleaning::** Use a mild soap (dishwashing liquid), warm water and a soft cloth or paper towel. Apply light pressure. Rinse with clear water; blot dry with a damp cloth or chamois. To remove oil or tar, use a good grade of hexane, aliphatic naphtha or kerosene. Use as recommended by manufacturer. Immediately wash away oily film residues with a mild soap and water solution. **DO NOT USE:** Window cleaning sprays, kitchen scouring compounds or solvents such as acetone, gasoline, benzene, carbon tetrachloride, ammonia or lacquer thinner. **CAUTION:** Alcohol and ammonia may cause crazing. **Dusting::** Dust with a soft, damp cloth or chamois. Dry or gritty cloths can scratch the surface. **Polishing::** Where necessary, wash with non-solvent auto paste wax to protect it and maintain its surface gloss. Apply a thin, even coat with a soft, clean cloth; polish lightly with cotton flannel. Wipe with a damp cloth to help eliminate electrostatic charges. **Expansion and Contraction::** Like most plastics, acrylic expands and contracts 3 to 8 times as much as glass or metals. Allow for size variation in frame systems and other fixtures. A 48" panel expands or contracts about 0.002" for each °F change in temperature. In outdoor use, where summer and winter temperatures differ as much as 100°F, a 48" sheet expands and contracts almost ¼" (0.20"), or approximately ± 1/8" from mid-temperature conditions. **Calculate** expansion and contraction allowances from your installing temperature measurements. To figure expansion and contraction, use a constant, the thermal expansion coefficient. The value for acrylic is 0.00004 in/(in.)(°F). Multiply panel length (inches) by the maximum possible temperature change and multiply the result by the coefficient. For example, if the temperature difference is 100°F (38°C) from winter night to noontime summer sun, an eight foot (96") acrylic sheet's length changes almost

3/8". Total Movement= Sheet Length X Temperature Difference X Coefficient = 96 in x 100 °F X 0.00004 = 0.38 in. For **installation**, expansion clearance = half-total movement. Most installations occur in the mid-temperature range (55-75°F or 7-22°C). If you install outside this range, figure clearances using the above formula. Acrylic absorbs water in high relative humidities, leading to expansion. At relative humidities of 100%, 80%, and 60%, respective dimensional changes are 0.5%, 0.3%, and 0.2%. A temperature and/or humidity difference on opposite sides of a sheet may cause slight bowing toward the higher value. As the differential lessens, the sheet resumes its original position. Dark-tinted acrylic (bronzes, grays excluding whites and ivories) with light transmission less than 60% and facing the south or southwest expand more than colorless sheet due to solar energy absorption. Movement of these panels is about 1.4 times that of colorless or lightly tinted sheet. For 96" (8 feet) of 131-2 Bronze (29% light transmission), it would be: Total Movement= Sheet Length X Temperature Difference X Coefficient= 96 in x 100 °F X 0.00004 = 0.38 in. *For dark-tinted sheet: movement = 0.38 in. X 1.4 = 0.53 in.*

Compatibility Acrylic is manufactured from polymethyl methacrylate, based on oil and natural gas. Some gasketing materials used with glass contain plasticizers (solvents). These can dissolve acrylic sheet, as can nail polish remover, paint thinner, or alcohol. As with cleaning, ammonia will cause the clarity to change. Codes and Regulations:: Acrylic meets the requirements of: ANSI Z97.1 for use as a Safety Glazing Material in Buildings (for thicknesses ≥ 0.080"). ANSI Z26.1 AS-4, 5, 6, & 7 for use as a Safety Glazing Material for Glazing Motor Vehicles, Federal Motor Vehicle Safety Standard 302; Flammability of Interior Materials, Federal Motor Vehicle Safety Standard 205; Safety Glazing. Building Codes for use as a Light Transmitting Plastic: See BOCA Evaluation Services, Inc., Research Report #94-30, See ICBO Evaluation Service, Inc.; Research Report #2158 and Refer to SBCCI PST & ESI Evaluation Report #93122 for Code Compliance State of Wisconsin Material Approval #950043-L, New York City MEA #145-80-M

POLYCARBONATE TYPICAL PROPERTIES:: Available in bronze, clear or white—although polycarbonate is more impact resistant than acrylic—it scratches easier. See page two for all of polycarbonate's physical properties.

STRUCTURED POLYCARBONATE:: (Bronze, Clear, Opal or other colors by special order)

Weight:: One-eighth the weight of glass—may not require the structural support glass may need **Bending::** Sheets must always be bent longitudinally—never across the width of the sheet **Strength::** Virtually unbreakable even when exposed to elevated outdoor temperatures over a long period of time—will maintain structural integrity. Resists cracking and splintering **UV Protection::** UV absorber is co-extruded onto the surface of the sheet forming a barrier against UV radiation **Flammability::** Classified in accordance with ASTM standards and do not give off toxic gasses.

Impact Resistance:: 8mm panel can withstand the impact of a 16 lb. weight falling 25 feet onto the panel with no breakage. Retains impact strength over a wide temperature range -40°F to 250°F. **Installation::** Protective PE film should be kept on sheet until installed. Uv protected side marked on PE film and should be faced towards the sun. Top and bottom ends of sheet must always be sealed by means of aluminum or vent tape to prevent dust or dirt inside. Tape can then be protected with framework or U-Channel.

BUTYL ARCHITECTURAL TAPE (1/16" x 3/8" x 50'):: An extruded, preformed architectural glazing tape furnished on release paper rolls. Based on a butyl rubber formulation with proven age and weather resistant properties, it is designed to create a long lasting, flexible weather seal between two surfaces which will be subjected to normal expansion/contraction and wind loading forces. The thickness is designed to be compressed approximately 10 percent at installation to accommodate surface alignments. Passes AAMA Spec. 807.3 and 804.3 for glazing tapes to be used with architectural aluminum.

Typical Properties:: Base Polymer: butyl rubber (polyisobutylene), Solids Content: 100% solids (no asbestos), Cure Time: fully cured before application, Hardness: 20 durometer Shore "A" @ 77°F (25°C) / 70 durometer Shore "00" @ 77°F (25°C), Temperature Range: Application -10°F (-23°C) to 120°F (49°C), 70 durometer Shore "00" @ 77°F (25°C), Service -45°F (-43°C) to 190°F (88°C), Joint Movement: ±15% of joint width, Service Life: 20 year minimum.

EPDM NEOPRENE GASKETS	Property	ASTM	Wedge Gaskets	Accessory Gaskets
Shore "A" Hardness		D-2240	68-71	58-62
Compression Set, 22h @ 100°C	Ozone Resistance, 100 mPa	D-395	22-28%	18-29%
100h @ 40°C, 20% Elongation		D-1149	No Cracks	No Cracks
Tensile Strength		D-412	1810-1925 psi (12.5-13.3 MPa)	1675-1750 psi (11.5-12.1 MPa)
Elongation @ Rupture		D-412	350-530%	375-550%
Tear Strength		D-624	143-209 lb/in (25.0-3636 kN/m)	160-18 lb/in (28.0-31.9 kN/m)
Brittleness Temperature @ -40°C		D-746	Pass	Pass
Flame Propagation, Option II		C-1166	No Limit	No Limit

FASTENERS:: Zinc Plated Carbon Steel Hex Washer Head Self-Drilling Screws

LSM Product	Nominal Size	Width Across Flats		Width Across Corners	Head Height		Washer Diameter		Washer Thickness	
		Max	Min	Min	Max	Min	Max	Min	Max	Min
SF / CM	6	0.25	0.244	0.272	0.093	0.08	0.328	0.302	0.025	0.015
FP Rail	10	0.312	0.305	0.34	0.12	0.105	0.414	0.384	0.031	0.019
FP Frame	12	0.312	0.305	0.34	0.155	0.139	0.432	0.398	0.039	0.022

Specification Requirements:: *Dimension: SAE J78 Drive Style: Hex Washer Head* *Material: Carbon Steel* *Point Style: Sizes 4 to 8, #2*
 Mechanical & Performance: SAE J78 *Thread Requirements: SAE J78* *Coating: Fe/Zn 3A per ASTM F1941* *Sizes 10 to 5/16", #3*

FRAMES:: All aluminum used in the manufacturing of skylights and retaining rails will be 6063-T5 aluminum (mill finish unless otherwise specified.)

CHEMICAL PROPERTIES FOR 6063 ALLOY

	SI	FE	CU	MN	MG	CR	ZN	TI	BO	AL
Minimum	.20	--	--	--	.45	--	--	--	--	Rem.
Maximum	.60	.35	.10	.10	.90	.10	.10	.10	--	

CURB MOUNT

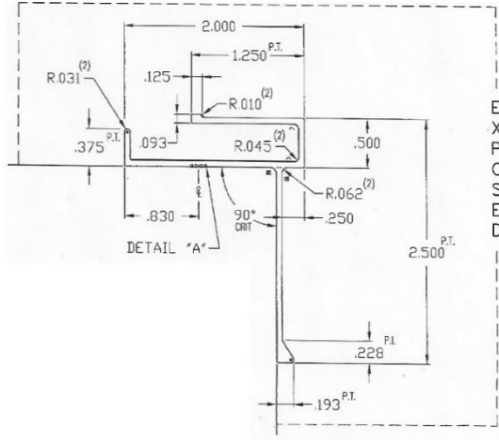

MULLION BAR & CAP

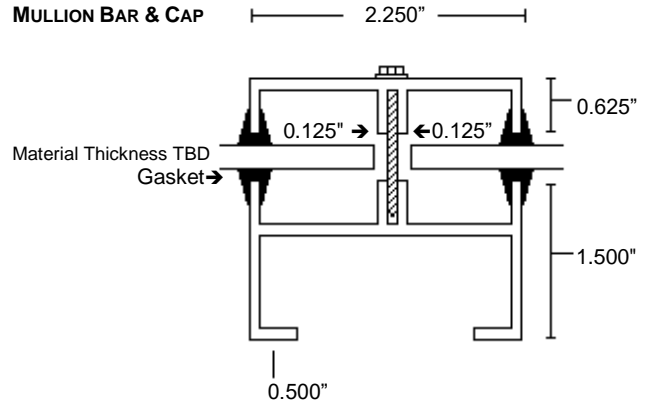

SELF-FLASHING

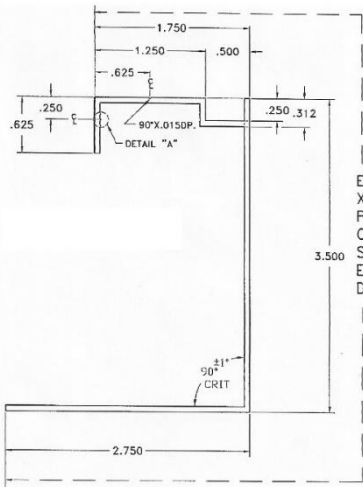

RETAINING RAILS

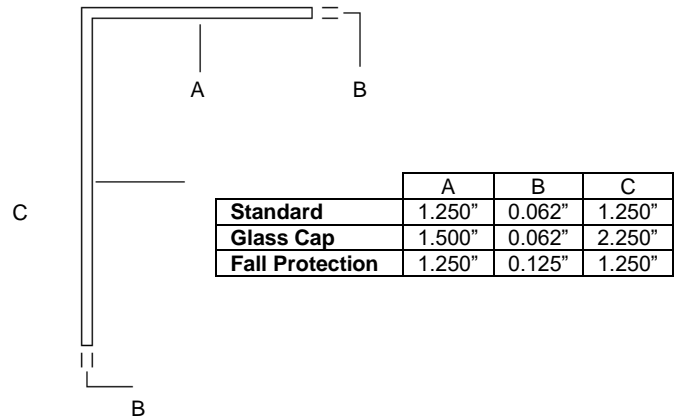

OTHER RETAINING RAILS AVAILABLE UPON REQUEST

CURB, INSULATED [NON-INSULATED]

Wood Nailer:: Dependent on height of curb—usually 2 x 9, but 2 x 6 and 2 x 12 or other height available

Insulation:: 1 1/2" (40 mm) Dow[®] Styrofoam[™] Extruded Polystyrene Insulation, minimizes the harmful effects of freeze-thaw cycles, weathering and physical damage during and after construction. Meets ASTM C578-01, Type VI—Standard Specification for Rigid Cellular Polystyrene Thermal Insulation. Standards Include: C518—Standard Test Method for Steady-State Thermal Transmission Properties by Means of the Heat Flow Meter Apparatus, D1621—Standard Test Method for Compressive Properties of Rigid Cellular Plastics, D2842—Standard Test Method for Water Absorption of Rigid Cellular Plastics, C272—Standard Test Method for Water Absorption of Core Materials for Structural Sandwich Constructions, E96—Standard Test Methods for Water Vapor Transmission of Materials, E84—Standard Test Methods for Surface Burning Characteristics of Building Materials, D696—Standard Test Method for Linear Thermal Expansion of Plastics Between -30°C and 30°C With a Vitreous Silica Dilatometer, C203—Standard Test Methods for Breaking Load and Flexural Properties of Block-Type Thermal Insulation, D2126—Standard Test Method for Response of Rigid Cellular Plastics to Thermal and Humid Aging. Code Compliances:: Meets IBC/IRC requirements for foam plastic insulation; see ICC-ES NER-699, ICBO-ES ER-2257, BOCA-ES RR 21-02, Underwriters Laboratories, Inc. (UL) Classified, See Classification Certificate D369 Factory Mutual Approved – Subject to conditions of approval as a roof insulation when installed as described in the current edition of FM Approval Guide, National Building Code of Canada, CCMC—Evaluation Listing #04888-L **Environmental Data::** Manufactured with HCFC blowing agents, which have 94 percent less ozone depletion potential than standard CFC blowing agents. Reusable in many applications

Physical Properties and Test Methods

	Value
Thermal Resistance per inch, ASTM C518 @ 75°F mean temp, ft ² · h · °F./BTU, R-value, min	5
Compressive Strength, ASTM D1621, psi, min	40
Water Absorption, ASTM C272, % by volume, max	0.1
Water Vapor Permeance, ASTM E96, perm, max	1.1
Maximum Use Temperature, °F	165
Coefficient of Linear Thermal Expansion, ASTM D696, in/in · °F	3.5 x 10 ⁻⁵
Flexural Strength, ASTM C203, psi, min	60
Dimensional Stability, ASTM D2126, % linear change, max	2.0
Surface Burning Characteristics, ASTM E84	
Flame spread	5
Smoke developed	165

Insulated

Custom

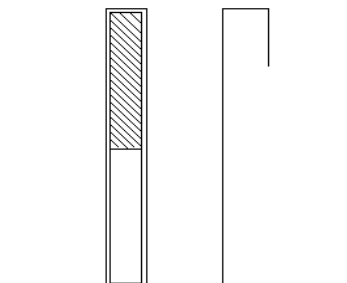

FLASHING:: 5052-H32P aluminum extrusion with a thickness of 0.040" and 3" deck flashing